

TECHNICAL SPECIFICATIONS

AU-RENE THEATER



BROWARD CENTER

— *for the* —

PERFORMING ARTS

Fort Lauderdale, Florida

Revised August 2017

TABLE OF CONTENTS

GENERAL CONTACT INFORMATION.....	2
MAP & DIRECTIONS.....	3
TRUCK, BUS & VEHICLE PARKING	3
SITE PLAN	5
LOADING DOCK INFO	6
SEATING CHART.....	8
STAGE SPECIFICATIONS	9
ORCHESTRA PIT / STAGE THRUST INFORMATION.....	9
STAGE DIMENSIONS / GROUND PLAN.....	10
RIGGING SPECIFICATIONS/OBSTACLES	13
SOFTGOODS INVENTORY	13
FOH RIGGING POINTS	14
HANGING PLOT / LINE SCHEDULE.....	15
SOUND AND COMMUNICATIONS.....	17
LIGHTING INFORMATION.....	21
POWER DISTRIBUTION.....	21
GENIE LIFT	22
DIMENSIONAL INFORMATION	23
LIGHT PLOT	24
ORCHESTRA EQUIPMENT / CONCERT SHELL INFORMATION	33
DRESSING ROOM / WARDROBE INFORMATION.....	35
BACKSTAGE MAP.....	38
PRODUCTION OFFICES	39
TELEPHONE LINES.....	40
LOCAL SERVICES (Ground Transportation & Lodging)	41
SHOPPING / OTHER SERVICES.....	45
MEDICAL: HOSPITAL AND DOCTORS	46

Au-Rene Theatre

at the

Broward Center for the Performing Arts

201 Southwest 5th Avenue

Fort Lauderdale, FL 33312

Main Office (954) 522-5334 (M-F 8:30A-5:30P)

Main Fax (954) 468-2549

Box Office (954) 468-3338

PRODUCTION STAFF

Director of Production	Tim Lessig	(954) 468-2557	tlessig@browardcenter.org
Production Manager	Chris Jahn	(954) 765-5802	cjahn@browardcenter.org
Production Manager	Lucas Bonewits	(954) 468-3317	lbbonewits@browardcenter.org
Production Supervisor	Diane DeChello	(954) 765-5819	ddechello@browardcenter.org
Production Coordinator	Rebecca Feldman	(954) 414-6906	rfeldman@browardcenter.org
Production Coordinator	Katie Byron	(954) 468-3319	kbyron@browardcenter.org
Production Coordinator	Jessica Mendoza	(954) 414-6376	jmendoza@browardcenter.org
Production Coordinator	Jimmy Rodgers	(954) 414-6386	jrogers@browardcenter.org
Production Fax		(954) 468-3315	
Stage Door Security Desk		(954) 468-3323	

EVENT SERVICES STAFF

Vice President of Operations	Shelly Bradshaw	(954) 468-2696	sbradshaw@browardcenter.org
Director of Event Services	Pablo Urquilla	(954) 468-3313	purquilla@browardcenter.org
Event Services Manager	Kerry McCloskey	(954) 414-6905	kmccloskey@browardcenter.org

STAGE LABOR - I.A.T.S.E. Local 500

The Broward Center for the Performing Arts employs members of I.A.T.S.E. Local 500 for all productions in the Au-Rene Theatre. Please contact Production Staff for labor rates and work rules.

Head Carpenter	Lou Falzarano	(954) 468-3334	louf_iatse@msn.com
Head Sound	Rachelle Hough	(517) 927-4257	rachellehough@yahoo.com
Head Electrician	Juan Zilveti ETCP	(954) 815-9340	juanzilveti@earthlink.net
Head Props	Sheila Walters	(954) 696-6411	sheilawalter77@yahoo.com
Head Wardrobe	Mary Soule	(954) 295-0977	soule2362@aol.com
Assistant Carpenter	Gary Kousek ETCP	(954) 604-3722	gary.1126@gmail.com
Assistant Carp/Flyman	Marc Stoudt	(954) 560-1510	mstoudtfl@bellsouth.net
Assistant Sound			
Assistant Electrician	Dudley Pinder	(954) 805-8609	stagedawg@gmail.com
Business Agent Local #500	Terry McKenzie	(954) 881-2353	termack500@gmail.com

ADDITIONAL CONTACTS INFORMATION

Vice President of Programming	Matt MacNeil	(954) 468-2551	mmcneil@browardcenter.org
Director Of Programming	Jill Kratish	(954) 468-3295	jkratish@browardcenter.org
Director of Guest Services	David Dillon	(954) 468-3305	ddillon@browardcenter.org
Director of Food & Beverages	Vinnie Venezia	(954) 468-3337	vvenezia@browardcenter.org
Admin. Mgr F&B – Merch	Shari Newberg	(954) 468-3336	snewberg@browardcenter.org

MAP & DIRECTIONS

The Broward Center is conveniently located in the Riverwalk Arts & Entertainment District in downtown Fort Lauderdale, equidistant between Dade and Palm Beach Counties and can be reached by several routes.

From Interstate-95:

Exit at Broward Boulevard, Go east.

From Florida Turnpike (southbound):

Exit at Sunrise Boulevard, Go East to South-bound I-95, exit Broward Boulevard, Go east.

From Florida Turnpike (northbound):

Exit at I-595, Go East to North-bound I-95, exit Broward Boulevard, Go east.

To Security Gate:

From Broward Boulevard turn right (South) onto SW 7th Avenue (Avenue of the Arts). Turn left at West Las Olas Blvd (the second light). Take an immediate left into the backstage lot security gate. Push the buzzer to contact guard. Identify yourself and guard will let you enter.

To Parking Garage and Valet:

Broward Boulevard. Turn South onto SW 5th Avenue. The Arts and Science Parking Garage is on the immediate right, or, proceed straight ahead, cross 2nd Street (Himmarshee St.) and continue to the top of the hill for valet service.

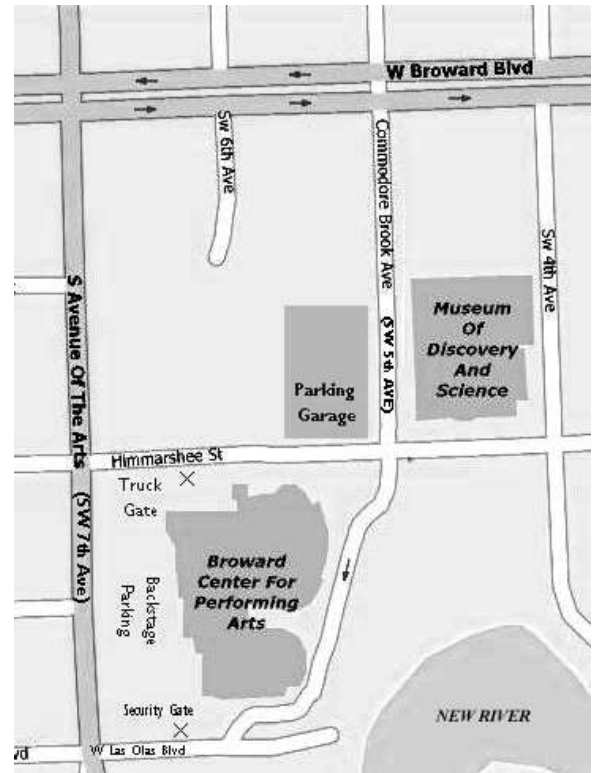

From Fort Lauderdale Airport to Backstage Lot:

Take the “US-1 / Federal Highway Northbound” exit out of the Airport. Travel North on US1 to SE 17th Street Causeway. Turn left (West) and go to SW 4th Avenue and turn right (North). SW 4th Avenue will become SW 7th Avenue at the bridge. Go over the bridge, turn right at West Las Olas Blvd . Take an immediate left into the backstage lot security gate. Push the buzzer to contact guard. Identify yourself and guard will let you enter.

North Gate - Trucks going to Loading Dock:

From Broward Boulevard turn South onto SW 5th Avenue. Turn right at Second Street (Himmarshee Street). The gate entrance to back-stage lot is on your left. Push the buzzer to contact guard. Identify yourself and guard will let you enter.

GPS Address (only for use with GPS!)

To the backstage Security gate:
641 West Las Olas Boulevard
Fort Lauderdale, FL

To the North Gate (truck & bus parking)
582 SW 2nd Street
Fort Lauderdale FL

TRUCK, BUS & VEHICLE PARKING

Truck & Bus Parking on site is very limited. Please inquire with Production Staff prior to arrival. There is parking available directly backstage in the lot for 15 cars and additional parking available for 40 cars in the Arts and Science parking garage located across the street from the theatre. All parking arrangements must be discussed with Production Staff prior to the event for necessary passes and badges.

BCPA Parking Lot



Broward Center Site Plan

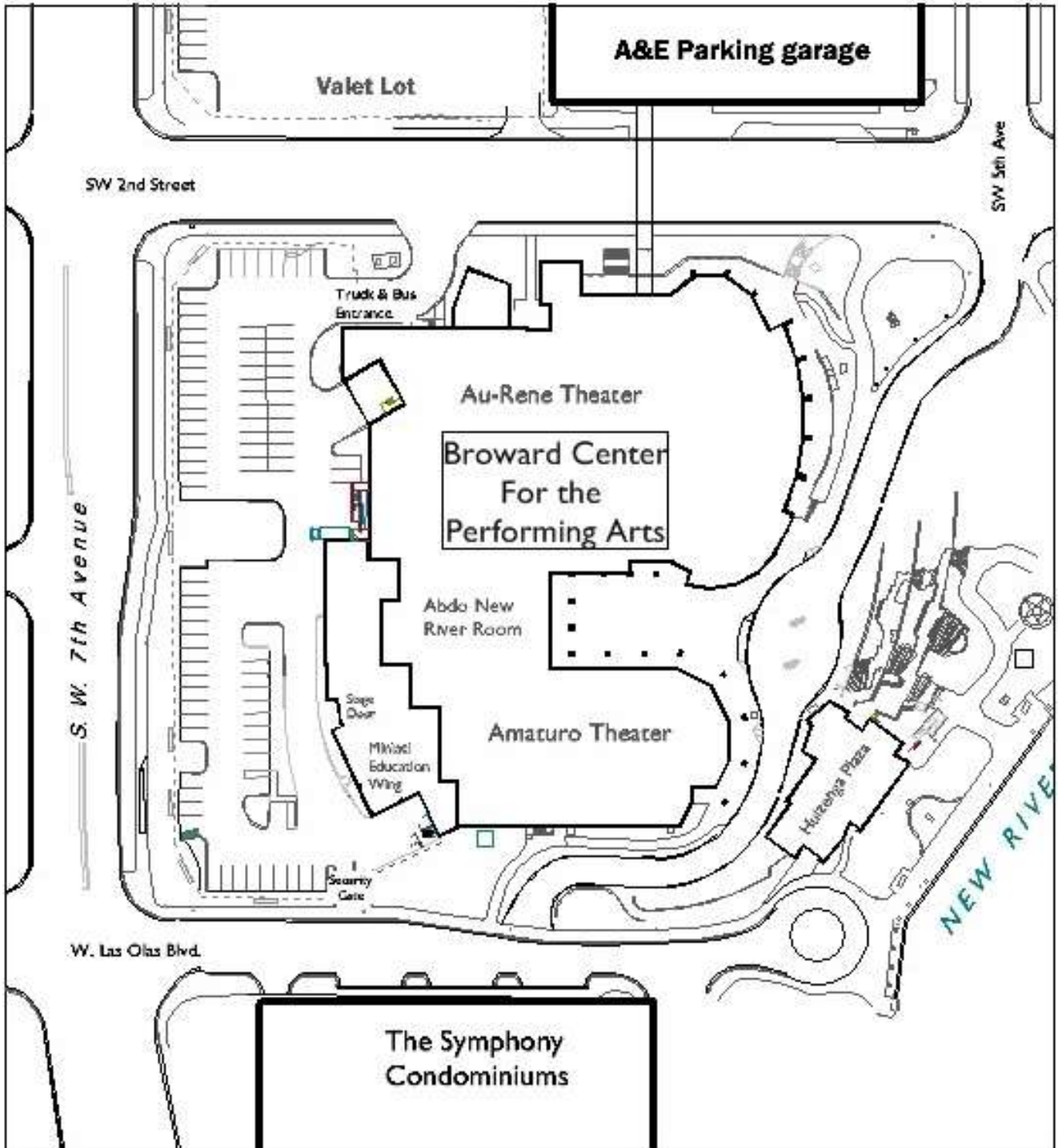

LOADING DOCK

The Au-Rene loading dock located on the northwest corner of the building at S.W. 7th Ave and Himmarshee Street. There are two loading bays. Loading Dock is 4' high and doors are 8'w x 12'h with 1,185 square feet of receiving area. Doors from receiving area to the stage are 11'-9" x 14'-0". Bus & Truck shore power is available. Only one truck or bus can remain in the loading dock after load in.

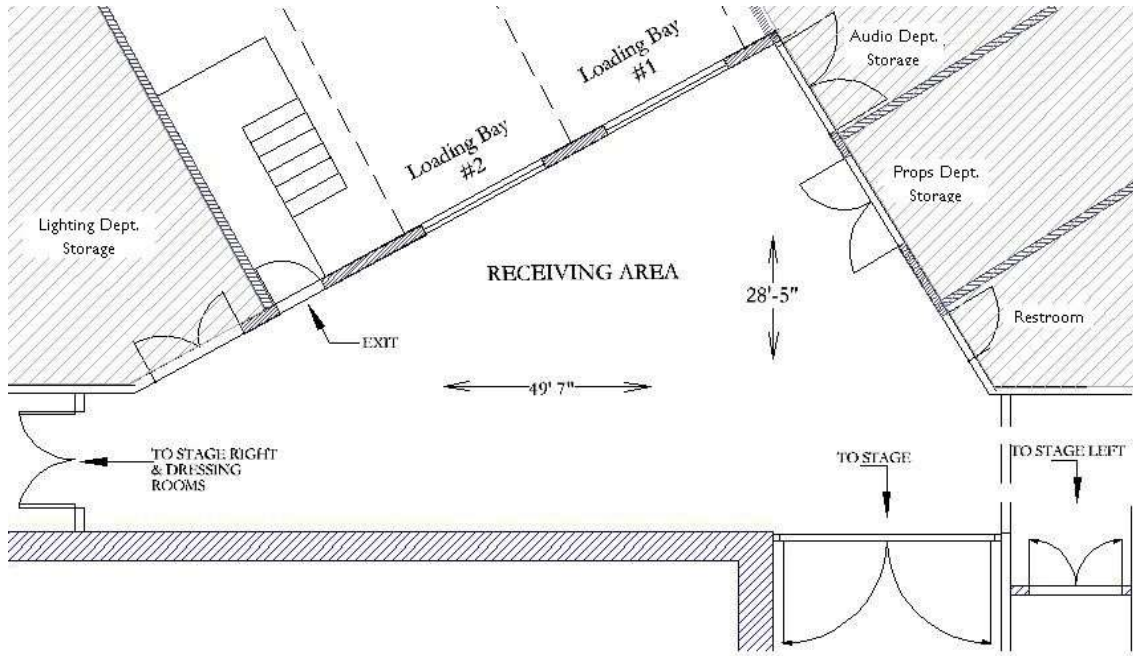

Au-Rene Theatre Receiving Area



SEATING INFORMATION AND CAPACITY

(MAXIMUM SEATING CAPACITY IS 2660 SEATS (See seating map on follow page)

Orchestra Level Total – 1556 Seats

Lower Orchestra Level (No Seat Holds)	Rows A - Z	820 seats
Upper Orchestra Level (No Seat Holds)	Rows AA - NN	674 seats
Orchestra Box Seats	Box A - H	30 seats
Standing Room	Behind row NN	32 "seats"
Stairs directly into audience	Remove row B seats 2-4 & 1-3	4 seats lost
Half Pit Configuration	Remove Rows A – C	39 seats lost
Full Pit / Full Thrust Configuration	Remove Rows A – F	107 seats lost
Kings Rows Center / Sound Mix Position	Remove Center Rows Y-Z	24 seats lost
Kings Row Left	Remove House Left Row Y, # 1-27	12 seats lost
Kings Row Right	Remove House Right Row Y, # 2-28	12 seats lost

Mezzanine Level Total - 506

Mezzanine Club Section	Row C-J	71 seats
Mezzanine Level	Rows A – K	411 seats
Mezzanine Box Seats	Box A, B, D & E	24 seats

Balcony Level Total - 630

Balcony Level	Rows A – N	614 seats
Balcony Box	Seats Box A & C	16 seats



View from stage of “full seating” configuration

SEATING CHART

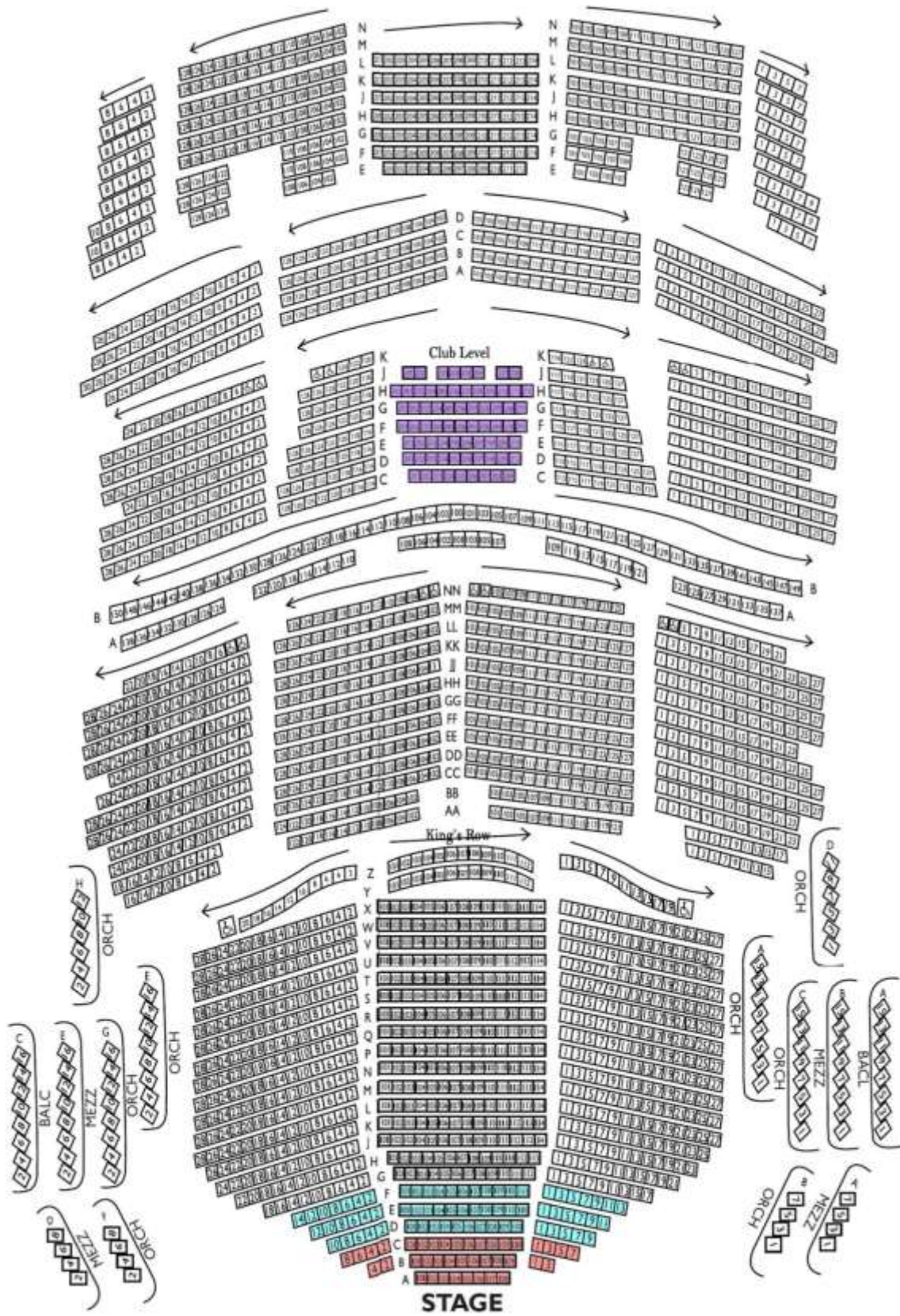

STAGE SPECIFICATIONS

STAGE FLOOR is a semi sprung floor with double layer tongue and groove plywood on aluminum sleepers over rubber blocks, and finished with black Stagelam®. The rubber blocks are surrounded by a steel channel which limits over-decompression. Any damage to floor incurred by a production must be restored at conclusion. Both Thrust configurations are curved; measurements given are long the centerline.

HEIGHT OF GRID	90'
HEIGHT OF PROSCENIUM	40'-4"
WIDTH OF PROSCENIUM	55'
HEIGHT OF GALLERIES	
Upper Loading Gallery	79' (top reach 89'-10")
Upper Operating Gallery/Pin Rail SR	37' (Catwalk is 32'-7")
Pin Rail SL	55' (Catwalk is 50'-7")
Upstage catwalk	50'
Floor Level Operating Rail SR	Stage Level
DEPTH OF STAGE (from Plaster Line)	50'
WIDTH OF STAGE	117'
Width of stage (center to SR)	56'
Width of stage (center to SL)	61'
CENTER STAGE TO PIN RAIL SR	41'
CENTER STAGE TO PIN RAIL SL	46'

ORCHESTRA PIT / STAGE THRUST

The Orchestra Pit is a Spira-lift in two sections. The pit can be configured as Half Thrust, Full Thrust, Full Seating, Full Pit, or Half Pit. Pit under-hang is 6'-0"

APRON (from Plaster Line)	2'- 4"
(from House Curtain)	3'-10"
FULL THRUST (from Plaster Line)	21'
(from House Curtain)	22'-06"
HALF THRUST (from Plaster Line)	11'-6"
(from House Curtain)	13'
HEIGHT OF STAGE (seating level to stage level)	3' 6"
FULL PIT Opening (Stage edge to DS pit wall)	18'-9" d
Overall Dimensions (including pit under-hang)	25' x 52'
Approximate Capacity of Musicians	62 musicians
HALF PIT Opening (Stage edge to DS pit wall)	10'- 9" d
Overall Dimensions (including pit under-hand)	17' x 52'
Approximate Capacity of Musicians	41 Musicians
HEIGHT OF PIT (pit level to stage level)	9'
HEIGHT OF STAGE (seating level to stage level)	3' 6"

AU-RENE STAGE: FULL SEATING

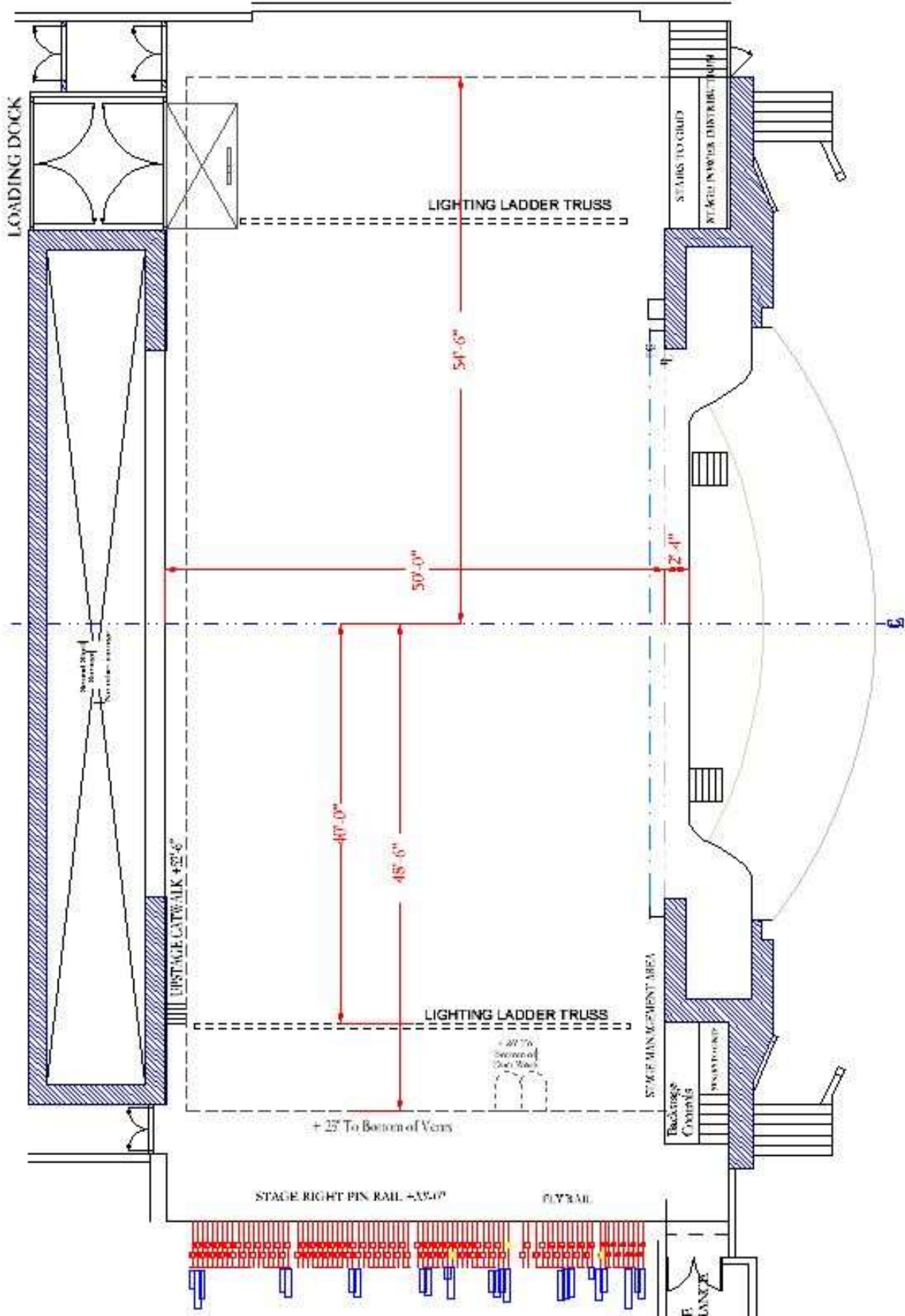

AU-RENE STAGE: FULL THRUST

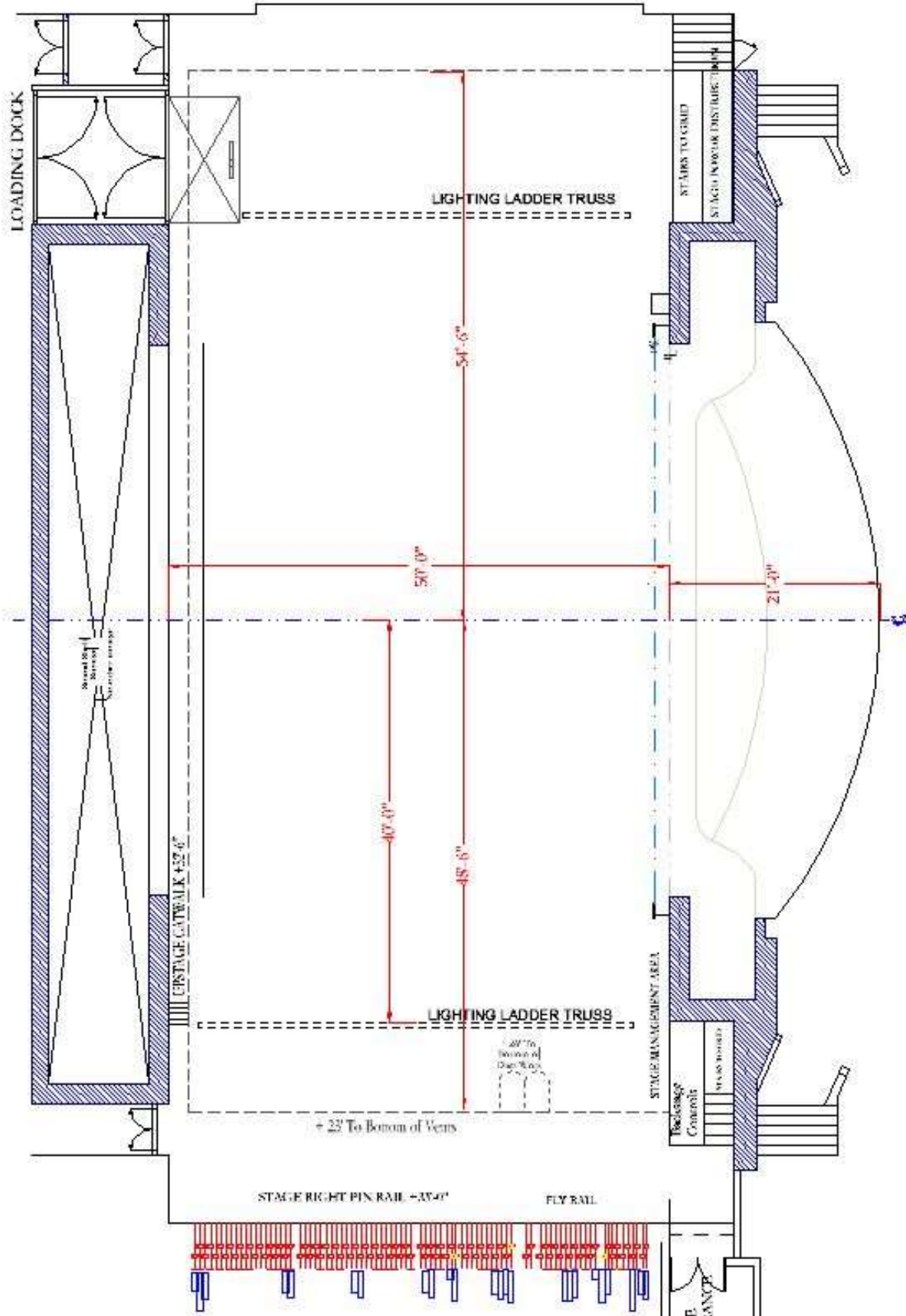

Au Rene Theatre: Center Line Section:

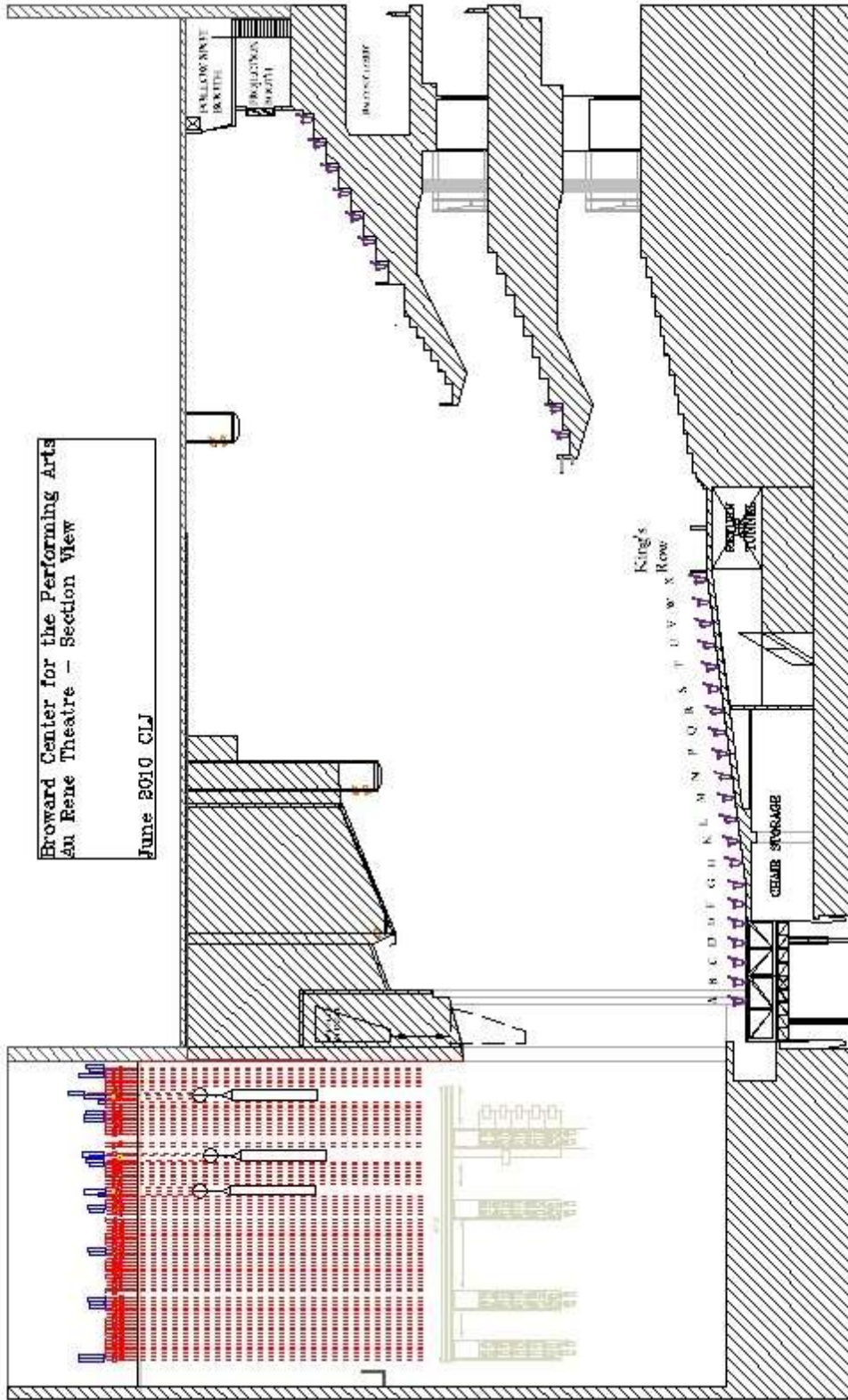

RIGGING SPECIFICATIONS

Counter weight system is a single purchase under-hung with 87 hand operated line sets and two operating positions available. One position located on stage level and the second position located 33' above stage right deck.

The grid is a Purlin Grid. Wells are located 5'-5", 16'-5", 27'-5" and 38'-5" L/R of center.

NUMBER OF AVAILABLE LINE SETS: 86 line sets 6" on center

GRID HEIGHT (Purlin Grid) 90'

TRAVEL DISTANCE 84'-3" (from "pipe in" position.)

MAX WEIGHT PER ARBOR 1,800 lb

TOTAL WEIGHT AVAILABLE 150,000

LENGTH OF BATTENS 63'

OBSTACLES

Line set 1 has a hard portal header and line set 2 has a set of adjustable hard portal legs. Portal header and legs are permanent and cannot be removed. Use line set 3 as first available.

There are three permanent orchestra shell ceiling panels; first shell is located between line sets 9 & 10. The second shell is located between line sets 24A & 25 and the third shell is located on line set 36. Line sets 9, 10, 24A, 25 and 37 have limited out trims (around 60') due to the proximity of orchestra shell ceilings. Avoid using these line sets for working pieces if possible. See line schedule for more out trim information.

HOUSE CURTAIN is motorized and operates at a maximum of 180 feet per minute, minimum 40 feet per minute. two halves with a three foot overlap. It is located 6' upstage from smoke pocket. House Curtain is permanent and cannot be shifted to another pipe, or removed.

SOFT GOODS INVENTORY

Description	Units	Height	Width
House curtain	1	43'	60'
Borders	1	44'	70'
Borders	6	16'	62'
Legs	4	43'	16'
Legs	8	43'	12'
Tabs	10	43'	6'
Split black drape	1	43'	62'
White filled scrim cyclorama	1	38'	62'
Translucent cyclorama	1	40'	62'
Black sharktooth scrim	1	38'	62'

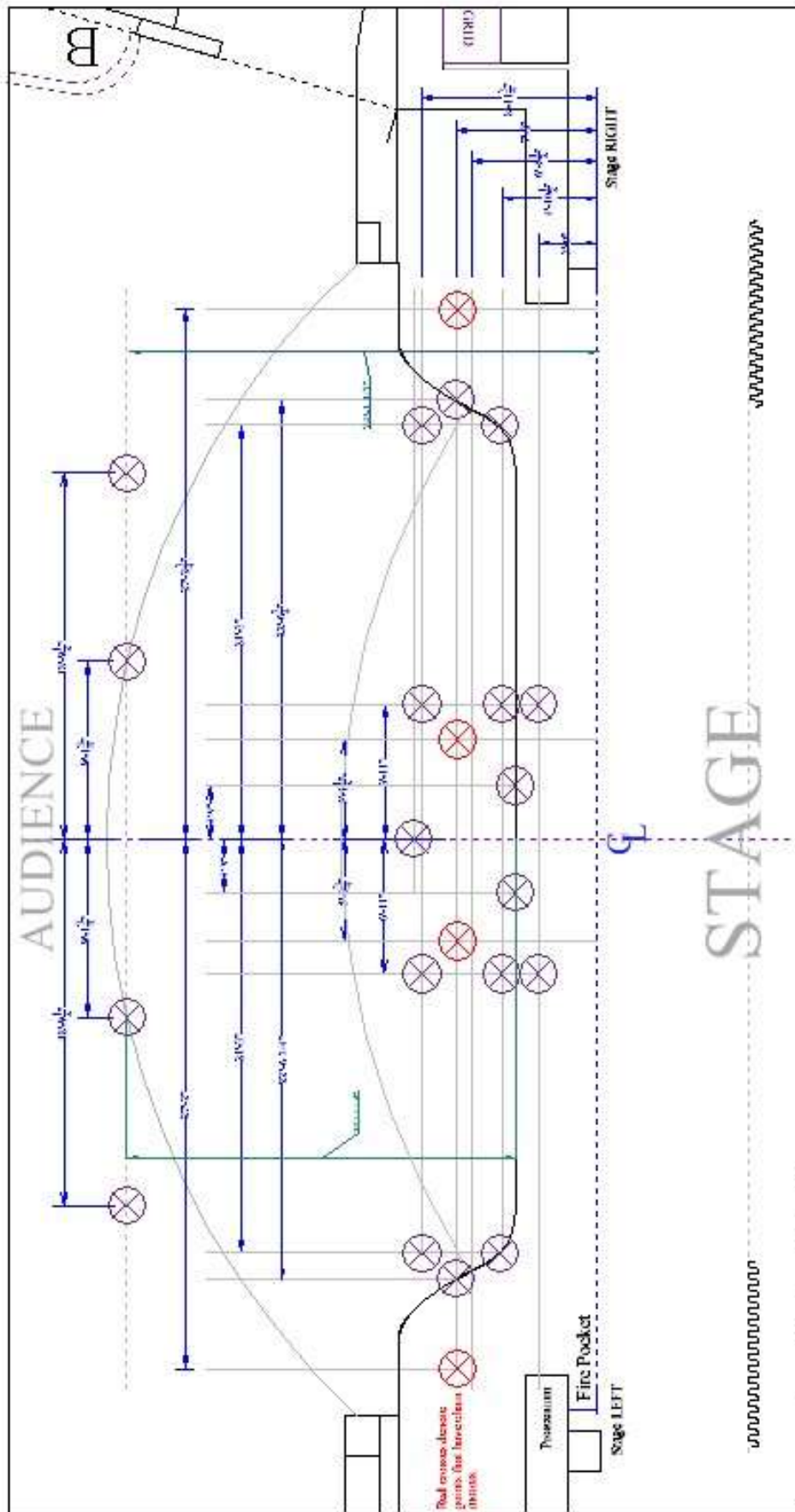

Au-Rene Rigging Point Plot
Anti-Proscenium

LINE #	POSITION	House Hang	Show Hang	Weight
	0'0"	Fire Curtain		
	0'5"	House Curtain (Red)		
1	1'2"	Adjustable Height Soft Portal Header	<i>Permanent Header</i>	
2	1'7"	Adjustable Width Hard Portal Legs	<i>Permanent Hard Legs</i>	
3	2'0"			
4	2'6"			
5	3'0"			
6	3'6"			
7	4'0"			
8	4'6"			
9	4'11"	Travel limited to 62' 10"		
	5' 2"	Orchestra Shell: bottom trim 62'-10"	<i>Permanent Orchestra Shell</i>	
10	5'4"	Travel limited to 62' 10"		
11	6'3"			
12	6'9"			
13	7'4"			
14	7'9"			
15	8'3"	House Black Border		
16	8'9"	House Black Leg SR		
17	9'3"	House Black Leg SL		
18	9'9"			
19	10'3"			
20	10'9"			
21	11'3"			
22	11'10"			
23	12'8"			
24	13'2"			
24A	14'3"	Travel Limited to 61' 4"		
	14' 6"	Orchestra Shell: Bottom Trim 61'-4"	<i>Permanent Orchestra Shell</i>	
25	14'8"	Travel Limited to 61' 4"		
26	15'4"			
27	15'9"	House Black Border		
28	16'0"	House Black Legs		
29	16'6"			
30	17'0"			
31	17'6"			
32	18'0"			
33	18'6"			
34	19'0"			
35	19'6"			
36	20'0"	Orchestra Shell: Bottom Trim 70' 9"	<i>Permanent Orchestra Shell</i>	
37	20'6"	Travel Limited to 70' 9"		
38	21'0"			
39	21'6"			
40	22'0"			
41	22'6"	House Black Border		
42	23'0"	House Black Legs		
43	23'6"			

LINE#	POSITION	House Hang	Show Hang	Weight
44	24'6"			
45	25'0"			
46	25'6"			
47	26'0"			
48	26'6"			
49	27'0"			
50	27'6"			
51	28'0"			
52	28'6"			
53	29'0"			
54	29'6"	House Black Border		
55	30'0"	House Black Legs		
56	30'6"			
57	31'0"			
58	31'6"			
59	32'0"			
60	32'6"	House Blackout Drop		
61	33'0"			
62	33'6"			
63	34'0"			
64	34'6"			
65	35'0"			
66	35'6"			
67	36'6"	House Black Border		
68	37'0"	House Black Legs		
69	37'6"	House Black Scrim		
70	38'0"			
71	38'6"			
72	39'0"			
73	39'6"			
74	40'0"			
75	40'6"			
76	41'0"			
77	41'6"			
78	42'0"			
79	42'6"			
80	43'0"			
81	43'6"			
82	44'0"			
83	44'6"			
84	45'0"			
85	45'6"	House White Cyc (filled scrim)		
86	46'0"	House Black Out Drop		

SOUND and COMMUNICATIONS

SPEAKER CONFIGURATION

The Au-Rene Theater has a stereo line array system, flown flanking the proscenium opening to cover the Orchestra and Mezzanine levels with a center sub array. Delay arrays provide coverage for the upper balcony, and the Under-Balcony Fills consist of ceiling mounted loudspeakers provide fill for seating located under the Mezzanine and Balcony overhangs. The side boxes have dedicated speakers aligned in three delay zones to improve intelligibility to these areas when the house arrays are flown out and touring arrays are utilized. The front fills service the first few rows of seating in the lower orchestra, and are housed in a continuous cavity along the front of the stage.

Main Arrays

The primary speaker system consists of two (2) Meyers Line Array of eleven (11) MICA speakers, flown on either side of the proscenium opening.

Sub Array

Sub-woofer center array consisting of (6) Meyer M3D cardioid pattern sub woofers.

Delay Arrays

The Delay Arrays consist of two (2) Meyers Line Array Cluster of five (5) MICA speakers.

Under-Balcony Fill

The mezzanine level under balcony fills consist of twelve (12) d & b Audiotechnik E8. The Orchestra level under balcony fills consist of four (4) E12-D speakers powered by three (3) d & b Audiotechnik D12 amplifiers.

Side Box Fills

The fill for the side boxes consist of (18) E6 speakers powered by (3) d & b Audiotechnik D-6 amplifiers.

Front Fills

The front fills consists EAW UBI2Si speakers powered by (3) d & b Audiotechnik D-6 amplifiers.

Patching

All systems are available for individual discrete patching at mix positions as well as DSL and DSR patch points

Audio Power

Audio power for the Au-Rene Theater is provided through a K-13 transformer delivering clean isolated power to all audio and video locations throughout the theater. The following locations are available company tie ins.

100 amp 3 phase company switch at DSL and DSR
(2) 20 AMP receptacles available DSR-DSL-USL-USR

SOUND MIX POSITIONS

There are three mixing positions available. You must discuss all seat holds for mixing positions with Production or Event Staff prior to tickets going on sale.

SOUND BOOTH – Located in the rear of the orchestra level approximately 140' from the stage. This position is in a sound booth under a balcony that has a window that can open and is approximately 8'd x 9'w. (located behind rows NN, seats 101-127 on seating map) Cable run is approximately 300'

ALT MIX -IN FRONT OF SOUND BOOTH - located in Rows MM & NN, seats 101 to 127 on seating map in rear of orchestra level approximately 135' from stage and is 6' -6" d and up to 22' w. (2 rows of fixed theatre seating must be removed to use this position - Additional labor charges may apply. Prior arrangement must be made with Production or Event Staff prior to ticket sale.) Cable run is approximately 300'

KING'S ROW – This is the preferred position located in center of orchestra level in Rows Y & Z, seats 101-114 on the seating map and is approximately 75' from the stage. This position is 24' wide, 7'- 8" deep, with a wall in front and back that is 2' 4" high. (2 rows of portable seating, approximately 24 seats, must be removed to use this position; please discuss with production or Event Staff prior to ticket sale.) cable run to this position is 250'



FRONT OF HOUSE CONSOLE

Digidesign VENUE Profile System 9935-55498-02 (24/8)

SOURCE GEAR:

(1) Yamaha CDX-550 CD player

MONITORS & MICROPHONES

NOTE: The following Monitor Equipment and Microphone package is shared with other venues at the Broward Center and may not be available for your event *unless prior arrangements have been made* with the Production Staff.

MONITOR CONSOLE:

Yamaha PM5D-RH

MONITOR SPEAKERS:

- 2 Shure in-ear monitors PSM700 w/ E3 SHU P7TRE3
- 14 powered wedge speakers Meyers MJF-210
- 2 Stage monitors Meyers USM-100P
- 4 Side Fill speakers Meyers UPQ-1P
- 4 powered subwoofer – dual 10” Meyers UMS-1P
- 2 EV 1502 ER
- 6 JBL MRX 512M
- 5 EAW VM12
- 4 Galaxy hot spots
- 7 Anchor AN 1001 X
- 1 Anchor AN 1000 self-powered
- 1 Galaxy Audio Hot Spot PAIII self-powered hot spot

Portable Microphone Splitter:

- 1 58 pair Whirlwind splitter with 1 direct out and 2 ISO splits
- 1 300' 58 pair mass connector
- 4 16 pair mic input sub snakes in lengths of 100' 75' 50' and 25'
- 1 16 pair 75' output sub snake

MICROPHONES

WIRED MICROPHONES:

<u>Manufacturer/Model</u>	<u>Quantity</u>	<u>Manufacturer/Model</u>	<u>Quantity</u>
Shure KSM 9	8	Sennheiser ME 66	4
Shure KSM 141	6	Sennheiser MD421U	3
Shure KSM 32	6	Sennheiser MD441	1
Shure Beta SM57	9	Earthworks PM 40	2
Shure Beta SM58	7	Electro Voice RE320	2
Shure SM81	5	Electro Voice RV18	3
Shure SM87A	6	Electro Voice RE20	4
Shure Beta 98A	8	Electro Voice DS35	4
Shure Beta 91	2	Whirlwind PB 12	2
Shure Beta 52	2	Beyer M160	4
Shure Beta 181S	4	Neuman KM 180	2
Shure Beta 56	6	Audio Tech AT857QMa	3
Shure Beta 57A	8	Audio Tech AT857QMLa	1
Shure WA310	12	Crown PCC 160	8
AKG C141 XLII/ST	2	Crown PZM LP6	3
AKG C214	2	Crown PZM 6RB	4
AKG C535	2	Crown GLM 200	2

Countryman ISOMAX 2	12	B & K 401 I	2
Countryman ISOMAX 2H	12		
Countryman M4HP5RF24EB	6		

WIRELESS MICROPHONES:

There are six (6) channels of Shure UR4D Diversity Receivers

- 6 Sure Beta 58 handheld transmitters
- 8 KSM9 alternate cartridge for handheld transmitters
- 6 UR1 Bodypack transmitters
- 3 Shure MKE 2 gold lavalier microphones
- 3 Countryman E6 earset microphones

There are 4 channels of SHURE U4D Receivers, Series J5, frequency agile 578-638 MHz

The following microphones are available for these receivers:

- 4 Shure U2 handheld transmitters w/Beta 87A capsules
- 4 Shure U1 bodypack transmitters w/Countryman B-3 mics

There are 8 channels of SHURE SLX Receivers, Series H5, frequency agile 518-548 MHz

The following microphones are available for these receivers:

- 2 Shure BETA SM87 handheld transmitters
- 8 Shure SLX bodypack transmitters w/Countryman B-3 mics

There are 8 channels of Shure SLX receivers, Series L4, frequency agile 638-662 MHz

The following microphones are available for these receivers:

- 2 Shure SLX handheld transmitters w/BETA SM87 capsules
- 8 Shure SLX Beltpacks w/Countryman B-3 mics

DIRECT INPUT BOXES:

- | | | |
|----|------------------------------|------------|
| 10 | Countryman FET 85 | Passive DI |
| 6 | Radial Engineering JDI MKIII | Passive DI |
| 4 | Radial Engineering JPC | PC DI |
| 2 | Whirlwind PCDI | PC DI |

BACKSTAGE COMMUNICATIONS

The Au-Rene Theatre is equipped with a ClearCom 4 channel intercom system; stations are located in the control booths, spot booths, and in the wings (including the fly rail).

- 1 PS-704 four channel power supply (supports up to 40 packs)
- 1 RM-704 four channel remote rack station
- 8 RS-601 wired beltpack (single channel)
- 4 RS-602 wired beltpack (two channels)
- 10 CC-26K-X4 single muff headsets (5 pin)
- 2 WBS-680/A2 wireless intercom transceivers
- 8 WTR-670 wireless beltpacks

LIGHTING INFORMATION

CONTROL

- 1 ETC Eos Console 8000, 2 monitors,
- 1 ETC Ion Console 1000, Universal Fader Wing 2 x 20, 2 monitors

FRONT OF HOUSE TRANSFER PANEL

Located DSL over Company switch - DMX in transfer available through board

POWER DISTRIBUTION

- 6 400 Amp 3-Phase disconnects DSL (2400 Amps total divided into 6 disconnects)
- 1 400 Amp 3-Phase disconnect USL
- 2 100 Amp 3-phase disconnects: (1)-USR, (1)-USL
- 1 400 Amp 3-phase Shore Power Panel (Lighting Storage/Loading Dock)
- 16 20 amps circuits located on each corner of the stage
- 2 30 amp circuits available on mezzanine

FOLLOWSPOTS

- 4 3k Lycian Followspots located in spot booth 158' from stage at a 25 deg angle

INSTRUMENT INVENTORY

This equipment is stored on racks in the Lighting Storage room, and is available for use as needed.

- 10 10 deg ETC Source 4 750W HPL
- 48 19 deg ETC Source 4 750W HPL
- 72 26 deg ETC Source 4 750W HPL
- 48 36 deg ETC Source 4 750W HPL
- 12 50 deg ETC Source 4 750W HPL
- 4 6" Fresnels 750W BTN
- 24 8" Fresnels 1K BVV
- 120 Par 64 1K M (available spare lamps: 45 VN; 76 N; 16 M; 52 W)
- 25 Par 56 strips: (12 cell/3 circuit) 300W Par 56 Med
- 6 Altman Far Cyc (3 cell/3 circuit) 1k FFT
- 7 T3 Ground Row – (6 cell/3 circuit) 1K FCM

ONSTAGE SIDE LIGHT LADDERS: Located 40' from CL.

SL/SR Ladders (4 adjustable ladders per side, instruments distributed equally to each)

- 32 ETC Source Four 26 deg 750W HPL (hung/circuited 2-1)
- 32 ETC Source Four 36 deg 750W HPL (hung/circuited 2-1)

FRONT OF HOUSE INVENTORY: These units are hung in the existing FOH lighting plot, and are not included in the general instrument inventory.

FAR CATWALK

- 36 ETC Source 4 5 deg 750W HPL (hung/circuited 1-1)

NEAR CATWALK

- 8 ETC Source 4 5 deg 750W HPL (4 hung/2 circuited 1-1, 4 not circuited)
- 24 ETC 10 deg 750W HPL (24 hung, 10 circuited 1-1, 14 not circuited)
- 36 ETC Source Four 19 deg 750W HPL (hung, circuited 1-1)

MEZZANINE RAIL

- 7 ETC Source 4 10 degree 750W HPL (hung/circuited 1-1)
- 14 ETC Source 4 19 degrees 750W HPL (hung/circuited 1-1)

BOX BOOM SL

- 20 ETC Source 4 19 deg 750W HPL (hung/circuited 2-1)
- 1 ETC Source 4 5 deg 750W HPL (spare for logo presentation)
- 10 ETC Source 4 10 deg lenses (spare)

BOX BOOM SR

- 20 ETC Source 4 19 deg 750W HPL (hung/circuited 2-1)
- 6 ETC Source 4 10 deg 750W HPL

APRON TORMS

- 4 ETC Source 4 19 deg 750W HPL (hung/circuited 2-1)
- 14 ETC Source 4 36 deg 750W HPL (hung/circuited 1-1)

HARDWARE INVENTORY

<u>units</u>	<u>Description</u>
50	City Theatrical Stacker Top Hats 6-1/4"
20	size "A" gobo Holders
20	size "B" gobo holders
12	Iris Slot gobo holders size "B"
100	gel frames
100	S4 Cardboard main frames 6-1/4"
10	5 deg S4 cardboard mainframe - 14"
20	10 deg S4 cardboard mainframes - 12"
511	Safety Cables
20	drop-in iris units
12	gel extenders 6-1/4
1	Look Solutions UNIQUE II Hazer
4	Par Lens Removal Tool American DJ
10	18' Booms with bases

GENIE LIFT

- 1 36' Genie AWP 36 lift (battery)

DIMENSIONAL INFORMATION:

Curtain line to Mezz rail	92' at 15 deg angle 90' from stage
Curtain line to Spot booth	158' at 25 deg angle
Curtain line to Near catwalk	65' at 55deg angle 40'-9" from stage Height 59'-6"
Curtain line to Far catwalk	118' - 7" at 40deg angle 92'-6" from stage Height 78'-4"
Curtain line to center of "King's Row" Alternate Sound Mixing Position	73'
Curtain line to Lighting booth	110'
Curtain line to Box Booms	66'-3" at 35 deg angle from top pipe - 55' from stage - Height 46'-3"
Curtain line to Box Boom Torm	55'-4" at 35 deg angle top of pipe - 20'-10" from stage - Height 41'-8"

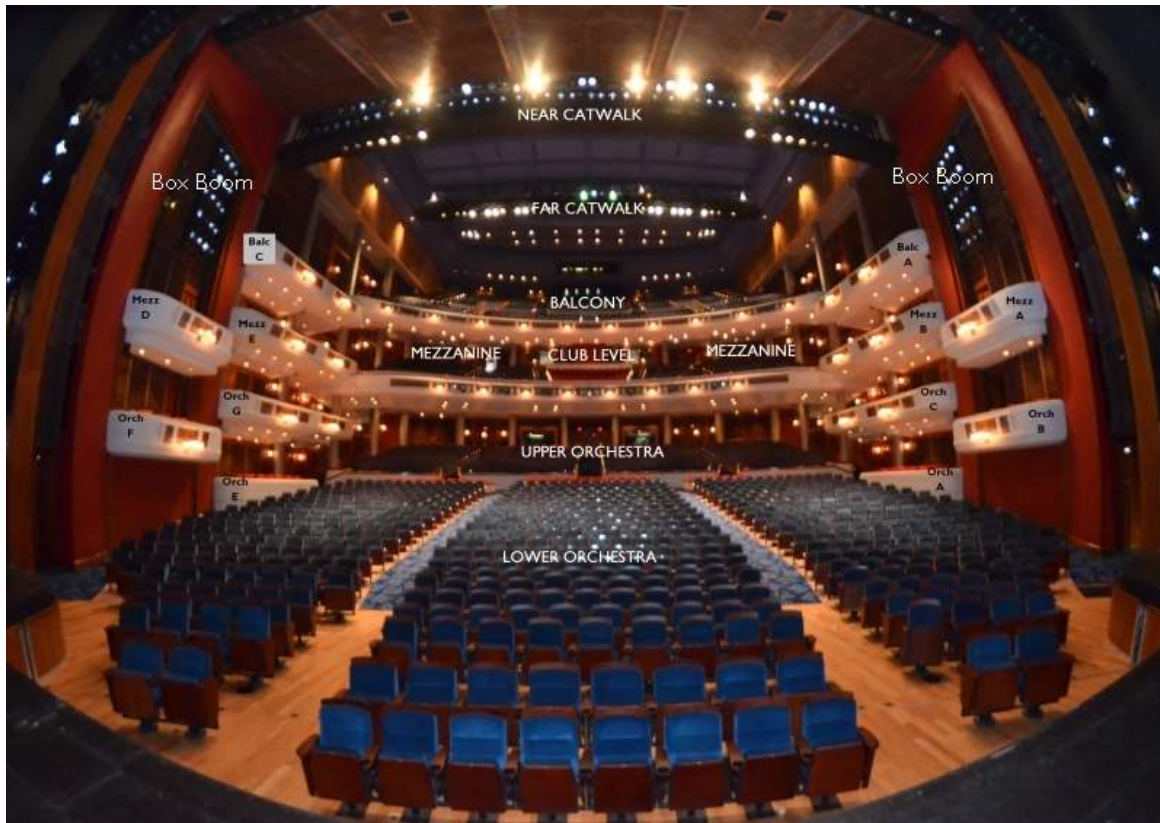

AU-RENE LIGHTING PLOT

An AutoCAD version of the complete plot is available upon request.

Mezzanine Rail
92'-0" to Plaster Line @ 15 deg angle
90'-0" to Stage
(14) 19 deg Source 4 ERS
(7) 10 deg Source 4 ERS

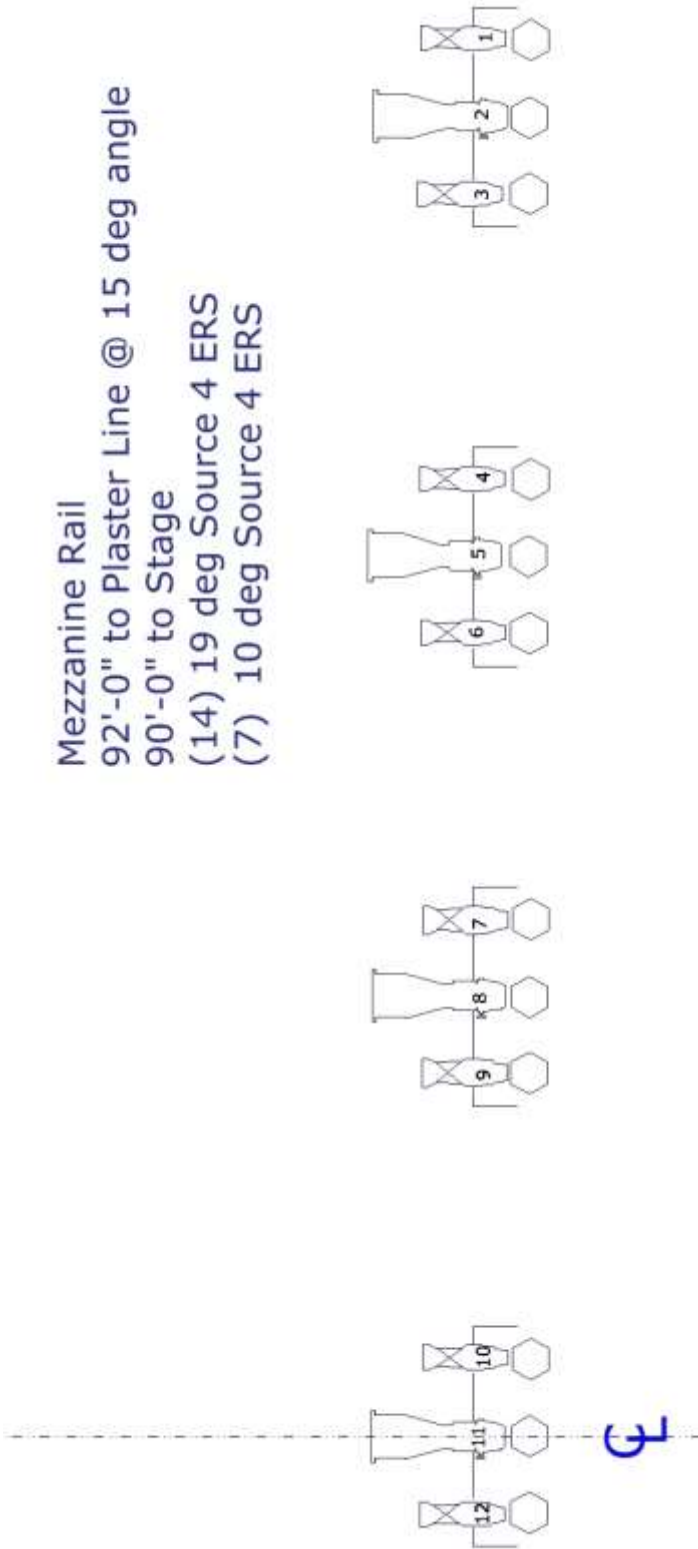

Mezzanine Rail
 92'-0" to Plaster Line @ 15 deg angle
 90'-0" to Stage
 (14) 19 deg Source 4 ERS
 (7) 10 deg Source 4 ERS

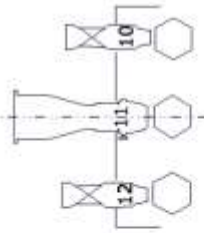
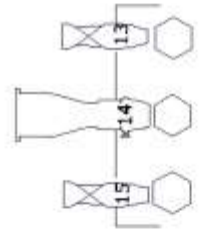
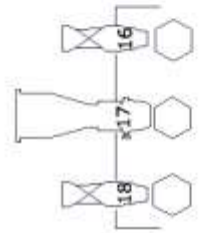
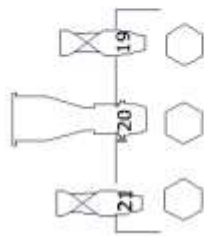

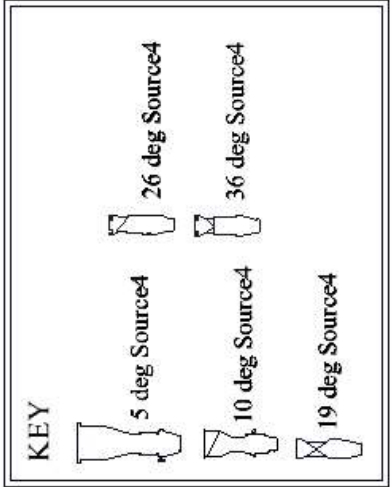
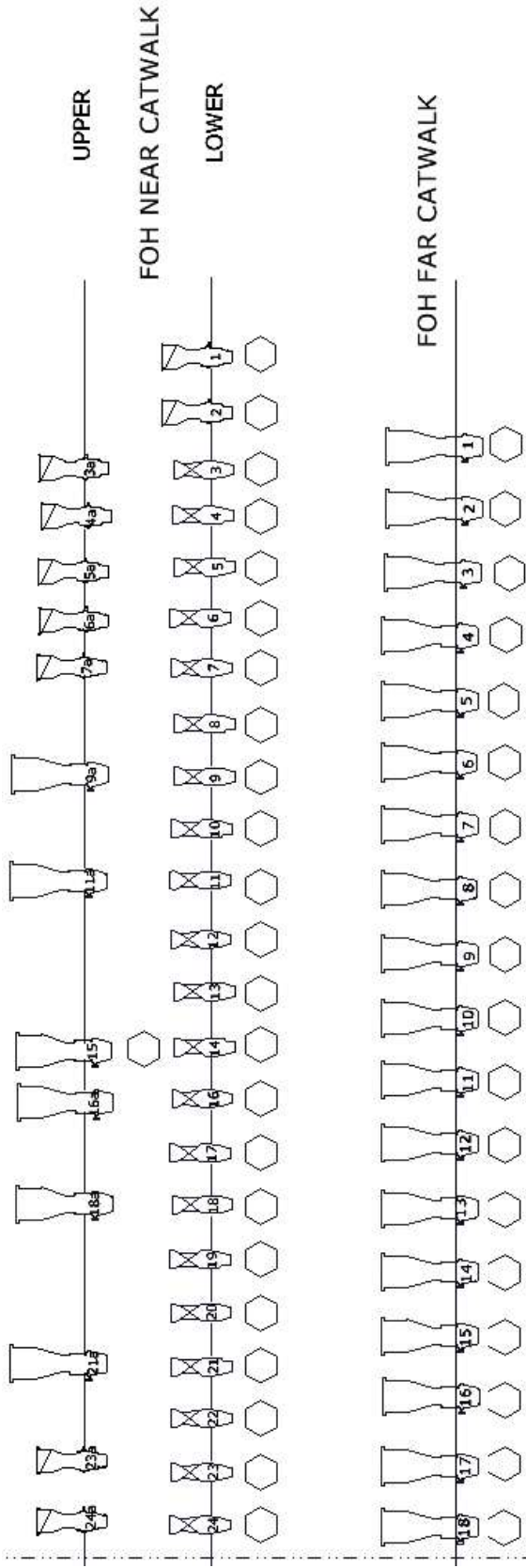

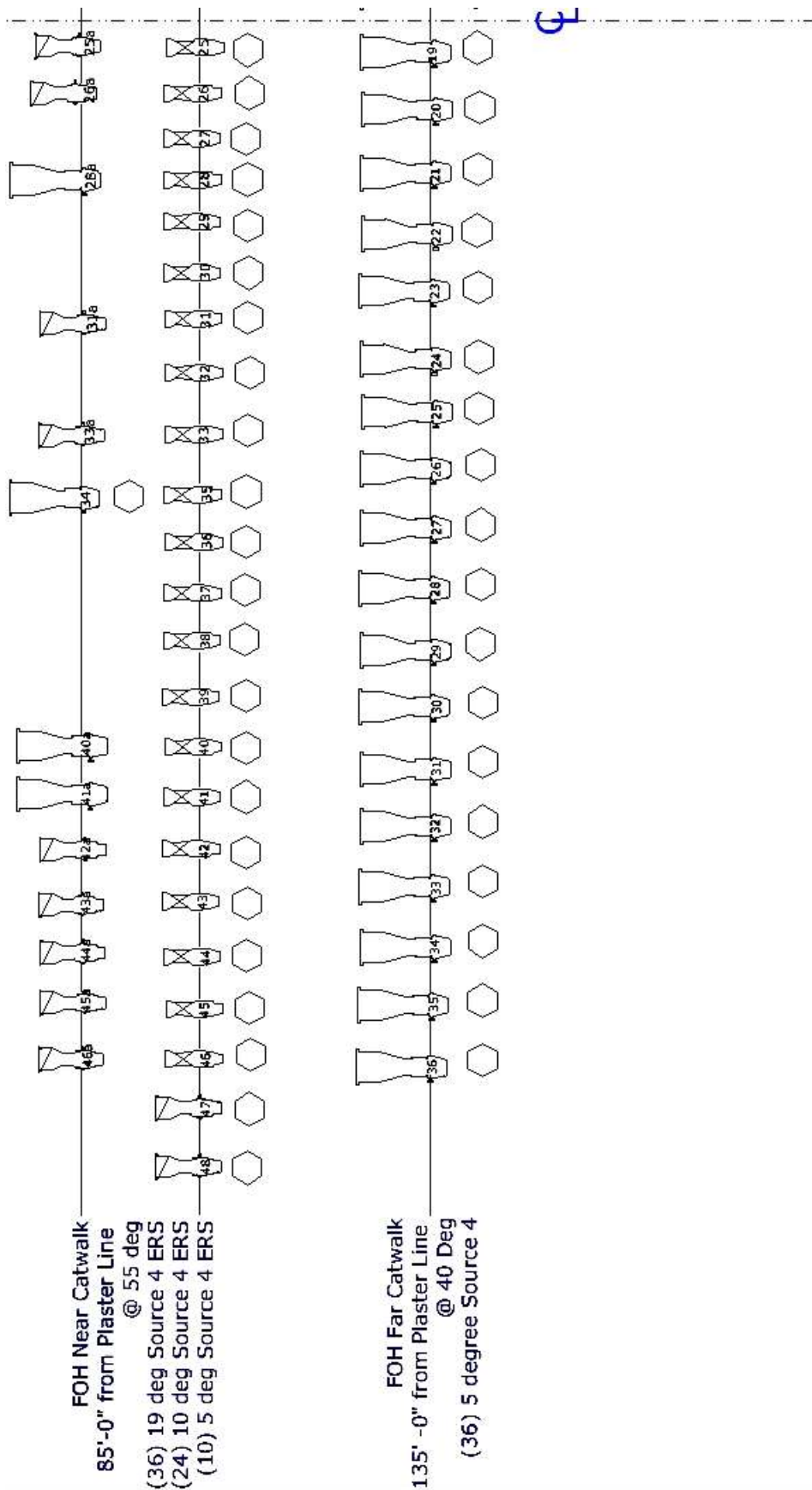

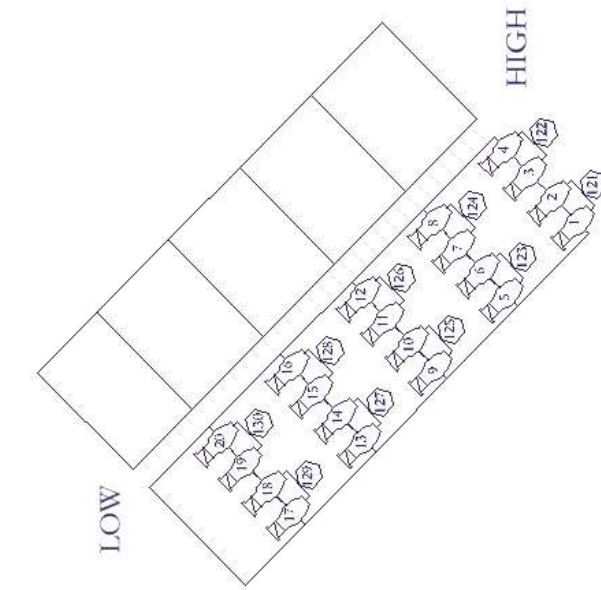

SL BOX BOOM
 60'-0" from stage @ 35 deg.
 (20) 19 deg Source 4

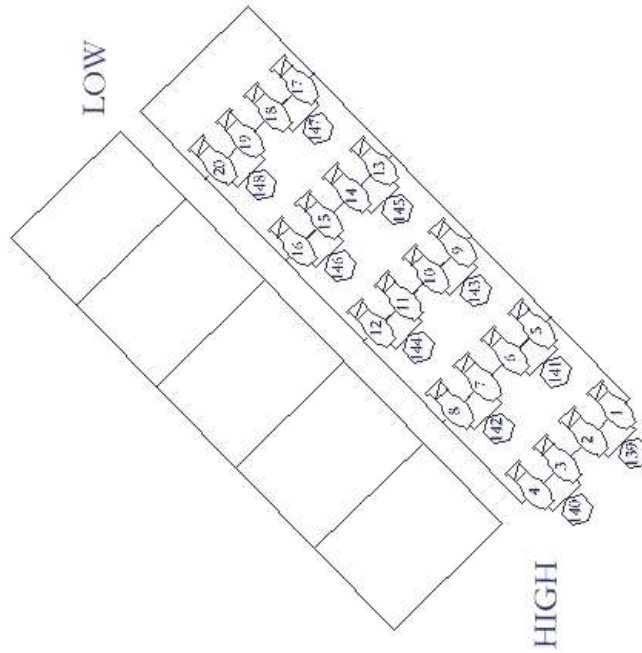

SR BOX BOOM
 60'-0" from stage @ 35 deg.
 (20) 19 deg Source 4

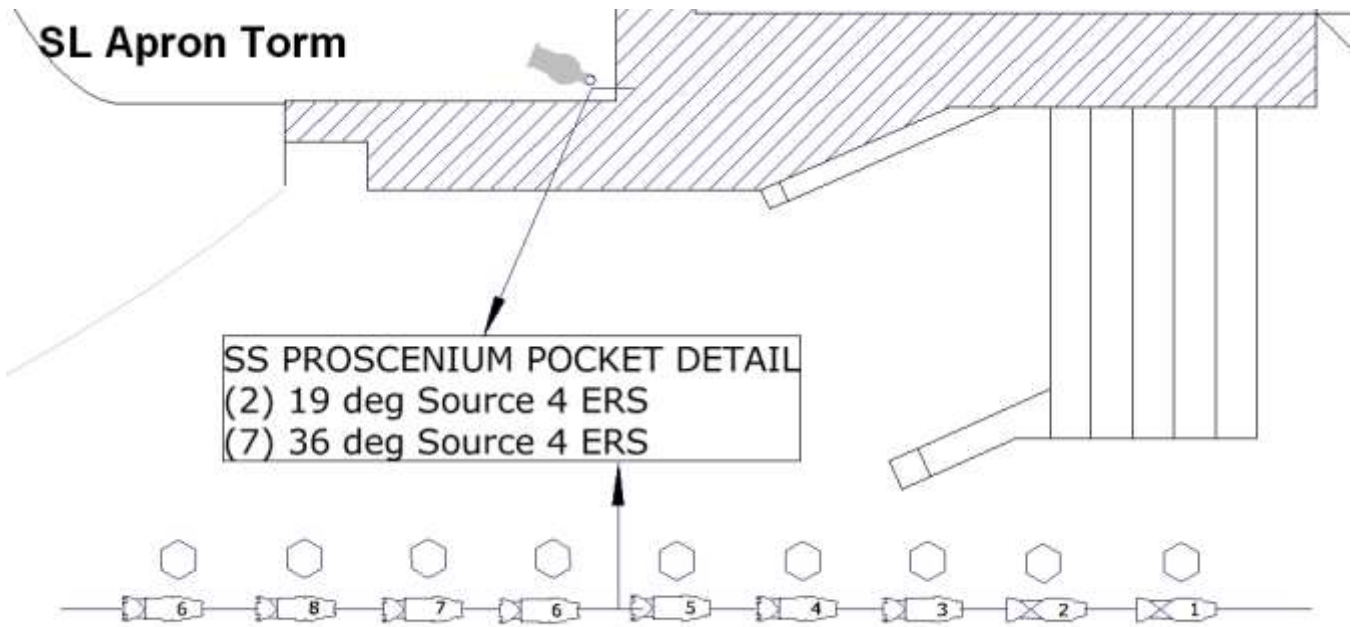
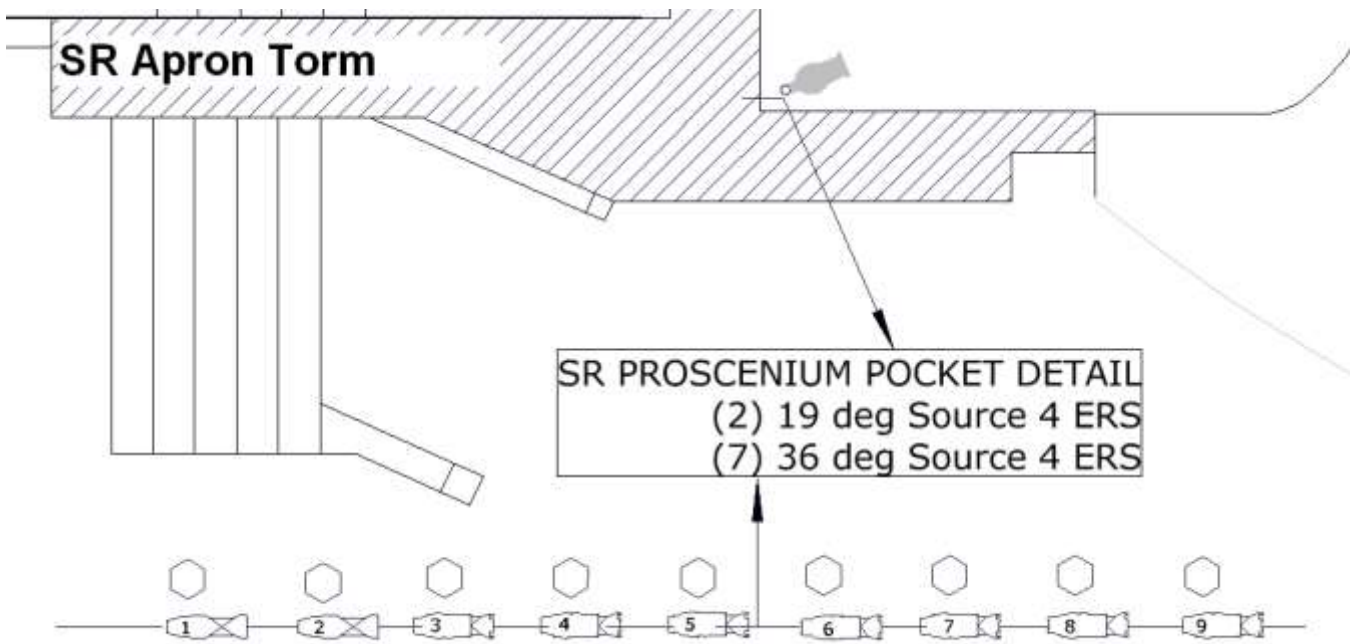

Au-Rene Light Ladders – Elevation View: (SL units shown)

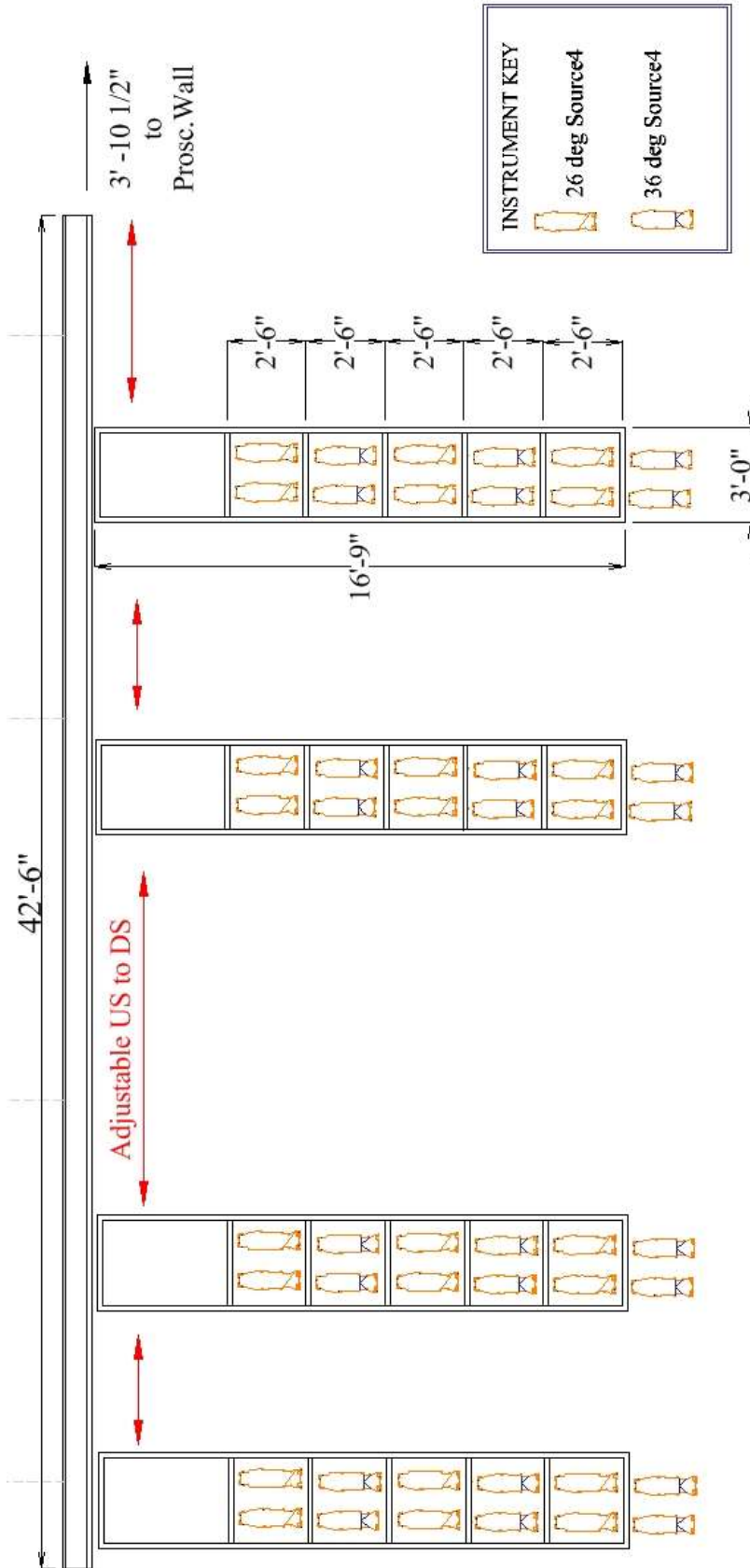

CIRCUIT LOCATIONS

CIRCUIT #	Location	Notes
1-39	Far catwalk	#7-9 are 208v/20amp
40-94	Near catwalk	#48-50, 75-77 are 208v/20amp
95-120	Mezz. Rail/Balc. Rail	#94-95 are 208v/30 amp
121-130	Box Boom SL Box Seat SL Box Seat SR	
140-149	Box Boom SR Lower Orch Box L Lower Orch Box R	
157-168	Inner Proscenium SL	
169-180	Inner Proscenium SR	
181-192	Floor DSR	
193-252	Breakout* SL	4'6" from PL, &DSL floor pocket
253-258	Breakout SL	4'6" from PL, &DSL floor pocket
259-264	Breakout SR	4'6" from PL, &DSR floor pocket
265-276	Breakout SL	8' from Plaster Line
277-282	Breakout SL	9'6" from Plaster Line
283-288	Breakout SL	10'6" from Plaster Line
289-294	Breakout SL	11'6" from Plaster Line
295-300	Breakout SL	13'6" from PL & MSL floor pocket
301-306	Breakout SR	13'6" from PL & MSR floor pocket
307-318	Breakout SL	16'6" from Plaster Line
319-324	Breakout SL	18'6" from Plaster Line
325-330	Breakout SL	19'6" from Plaster Line
331-336	Breakout SL	20'6" from Plaster Line
337-342	Breakout SL	22'6" from PL & MSL floor pocket
343-348	Breakout SR	22'6" from PL & MSR floor pocket
349-360	Breakout SL	25' from Plaster Line
361-366	Breakout SL	27'6" from Plaster Line
367-372	Breakout SL	28'6" from Plaster Line
373-378	Breakout SL	29'6" from Plaster Line
379-384	Breakout SL	31'6" from PL & MSL floor pocket
385-390	Breakout SR	31'6" from PL & MSR floor pocket
391-402	Breakout SL	34'6" from Plaster Line
403-408	Breakout SL	36'6" from Plaster Line
409-414	Breakout SL	37'6" from Plaster Line
415-420	Breakout SL	38'6" from Plaster Line
421-432	Breakout SL	39'6" from Plaster Line
433-444	Breakout SR	39'6" from Plaster Line
445-450	Breakout SL	40'6" from PL & USL floor pocket
451-456	Breakout SR	40'6" from PL & USR floor pocket
457-462	Pin Rail SL	
463-465	Pin Rail SL	463-464 are 208v/20amp, 465 is 50amp
466-471	Pin Rail USL	
472-477	Pin Rail SR	
478-480	Pin Rail SR	478-479 are 208v/20amp, 480 is 50amp
481-486	Pin Rail SR	
487-492	DSL Wall	
493-495	DSL Wall	208v/20amp

496-501	DSR Wall	
502-504	DSR Wall	208v/20amp
505-510	USL Wall	
511-513	USL Wall	511-512 are 50 amp, 513 is 208v/20amp
514-543	USR Wall	
544-546	USR Wall	544-545 are 50 amp, 546 is 208v/20amp

NON-DIMS

A,B,C located FOH

D,E,F located on Pin Rails

G,H,J,K,L,M located DS and US L&R

CUE LIGHTS

I-6 DSL, DSR, USL, USR and UPPER INDEX

BREAKOUTS

All breakouts consist of 6 stage pin connectors.

ORCHESTRA EQUIPMENT AND CONCERT SHELL

ORCHESTRA EQUIPMENT

96	Wenger Orchestra Chairs
6	Cello Chairs
87	Music Stands w/lights
1	Conductor's Podium and Stand
10	Stools
10	3'x 6' Tables

RISERS: Black skirting is available for risers

10	4'x 8'x 8''h
10	4'x 8'x 16''h
10	4'x 8'x 24''h

STEP UNITS:

2	8'' single step units
2	16'' step units
2	24'' step units

PIANOS (Note: Pianos tuned only by House Tuner Only - tuning not included)

2	9' Steinway Concert Grand Model D
1	7' Steinway Baby Grand Model B
3	Yamaha Uprights

ORCHESTRA CONCERT SHELL:

There are four concert shell units that are forty-one feet tall, 20' -9'' across, and 8'-6'' deep; the two side units have double doors built in to allow entrances on both sides of the stage, just above the proscenium. Once the shell units are placed, pre-hung ceiling units are flown in to complete the shell. When completely assembled, the shell is architecturally consistent with the rest of the hall. The shell units are designed to play in one of two configurations:

- Shallow Setting which is 17' deep and 39' wide at the rear, with entrance doors DL and DR.
- Deep Setting which is 26' deep, and 39' wide at the rear, with entrance doors DL and DR.

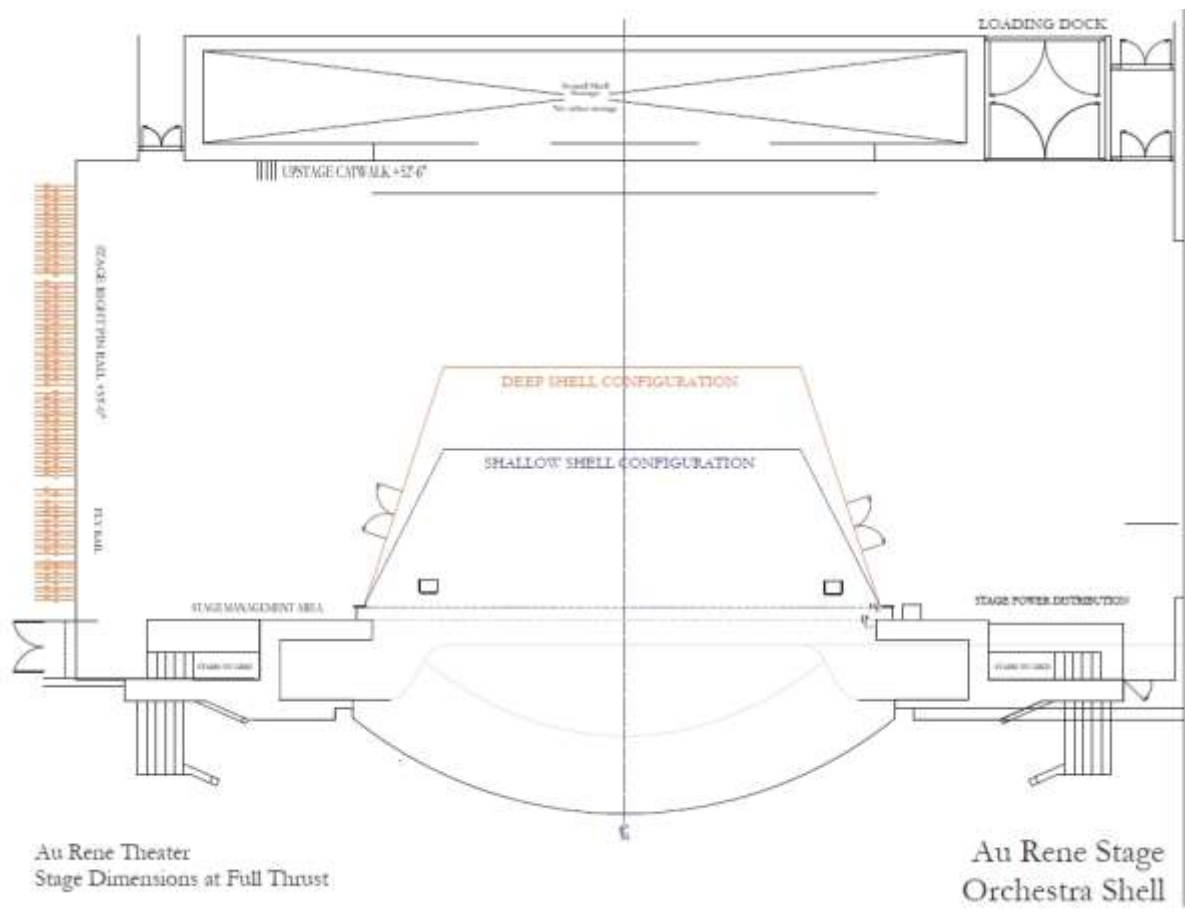

The orchestra shell in shallow configuration with full thrust stage.

DRESSING ROOM / WARDROBE / GREEN ROOM INFORMATION

DRESSING ROOMS:

All dressing rooms are located off stage right. All rooms are equipped with showers, toilets, mirrors and chairs. Rooms and 144-145 are the Star/soloist dressing rooms with a small reception area, wet bar and private bath. Rooms 121-122, and rooms 141-142 can accommodate 2-4 people, rooms 123-128 can accommodate 8-10 people. Dressing Room #122 has a door connecting directly to the ADA compliant restroom; this door is locked unless an ADA compliant dressing room is requested. See dressing map on the following page for location.

Dressing Room #	Number of People	Dimensions
Room #121	2 – 4 person	9' W x 10' L
Room #122	2 – 4 person (ADA available)	9' W x 10' L
Room #123	8 - 10 persons	8'-6"W X 24' 8"L
Room #124	8 – 10 persons	8'-6"W X 24' 8"L
Room #125	8 - 10 persons	8'-6"W X 24' 8"L
Room #126	8 - 10 persons	8'-6"W X 24' 8"L
Room #127	8 - 10 persons	8'-6"W X 24' 8"L
Room #128	8 - 10 persons	8'-6"W X 24' 8"L
Room #141	2 - 4 persons	9' W x 10' L
Room #142	2 - 4 persons	9' W x 10' L
Room #144 - Star DR	1 person	2 Room Suite
Room #145 - Star DR	1 person	2 Room Suite



WARDROBE ROOM:



There is no dedicated Wardrobe room at the Broward Center, just a small room for minor repairs.

The Show's Wardrobe Department has the option of setting up in a dressing room or the Au-Rene Green room. Arrangements should be discussed with Production Staff prior to the company's arrival.

LAUNDRY ROOM:

The center has one laundry room to facilitate both theaters. It is located on stage level between the two theater spaces. The "wardrobe room" really works as a laundry area. Three washers and three dryers are on hand. Double sink is available. Most shows opt to use Dressing Room 123 as a wardrobe workroom, if one is required.



GREEN ROOM / REHEARSAL - WARMUP ROOM/ CATERING ROOM:



The Au-Rene Green Room is 38'-8" x 16'-10" and has a small kitchen area with a microwave, coffee maker, sink and refrigerator.

It can be used as a Catering Room, a Wardrobe Room, a Production Office or a Rehearsal/Warm-up room.



It has one wall of mirrors and barres, a wood floor (no rosin allowed) and can be set to have five phone lines and a data port.

There are also barres and mirrors located in the hallway across from dressing rooms 127 and 128, and in the hallway across from the stage entrance to Down Stage Right.



PRODUCTION OFFICES:

The Au-Rene theater is equipped with office space for touring acts. There are three rooms set up specifically for use as offices and the Green room the can be converted for office space if needed. These offices are located adjacent to the dressing rooms, off stage right of the theater. Each room has phone and network connections, folding tables, and chairs. Please note that there are additional fees for use of internet and phone. Calling Card or code required for all long distance calls. The default arrangement is as follows:

STAR MANAGER'S OFFICE:

The Star Manager's Office is directly across from the Star Dressing rooms. It is 8'-10" by 8'-4". It has two phone connections and one dataport.



STAGE MANAGER'S OFFICE

The Stage Manager's office is located between the Star Dressing Rooms and the Chorus Dressing Rooms, facing the Green Room. It is 11'-0 by 8'-10". It has three phone connections and one dataport.



COMPANY MANAGER'S OFFICE

The Company Manager's Office is located between the Star Dressing Rooms and the Chorus Dressing Rooms, facing the Green Room. It is 11' by 8' 10". It has three phone connections and one dataport.

TELEPHONE NUMBERS:

There are a total of (8) eight phone lines available for use in the backstage areas of the Au-Rene Theater. There are (6) digital phone lines that require BCPA handsets, and (2) analog lines that will work with fax machines, standard handsets or personal voicemail systems. The BCPA handsets include voicemail. These can be patched as needed in our various backstage rooms.

Digital Numbers:

954-660-6340
954-660-6341
954-660-6342
954-660-6343
954-660-6344
954-660-6345

Analog Numbers:

954-660-6346
954-660-6347

LOCAL SERVICES

GROUND TRANSPORTATION

Checker Taxi
954-923-9999

Yellow Cab
954-777-7777

Broward County Transit
954-357-8400
www.Broward.org/bct

A Personal Touch Limousine Service
800-741-2785
<http://www.aptilimo.net/>

Water Taxi
954-467-6677

Sun Trolley
954-761-3543

Tri-Rail
(800) 874-7254
www.Tri-rail.com

LODGING INFORMATION

The Broward Center for the Performing Arts maintains several official lodging partners. If your organization is seeking housing, please contact the following properties and identify yourself as an artist, crew or patron of the Broward Center. The hotel will give you our special rates if available.

Hampton Inn
250 N. Andrews Ave.
Fort Lauderdale, FL 33301
954.924.2700
hamptoninnftlauderdale.com

Sonesta Fort Lauderdale
999 North Fort Lauderdale Beach Blvd
Fort Lauderdale, FL 33304
954-315-1460
www.sonesta.com/fortlauderdale

**Galleryone Fort Lauderdale-
A Doubletree Suites by Hilton**
2670 East Sunrise Boulevard
Fort Lauderdale, FL 33304
954-565-3800
www.galleryone.doubletree.com

Riverside Hotel
620 E. Las Olas Blvd.
Fort Lauderdale, FL 33301
800.325.3280
riversidehotel.com

Ritz-Carlton Fort Lauderdale
1 North Fort Lauderdale Beach Boulevard Fort
Lauderdale, FL 33304
954-465-2300
www.ritzcarlton.com/fortlauderdale

BANKING

Sun Trust Bank
601 W. Broward Blvd
Fort Lauderdale, FL 33312
954-713-1492

Bank of America
401 East Las Olas Blvd
Fort Lauderdale, FL 33301
954-524-6581

Wells Fargo
1 East Broward Blvd
Fort Lauderdale, FL 33301
954-762-9200

COPIES/PRINTING

FedEx Office
300 North Federal Highway
Fort Lauderdale, FL 33301
954-467-1007

Reprograffia (Blueprints)
801 N. Andrews Ave
Fort Lauderdale FL 33301
954-525-0157

DELIVERY SERVICES

US Post Office
400 NW 7th Ave
Ft. Lauderdale, FL 33311
(800) ASK-USPS
954-523-0327

The Broward Center has regularly
scheduled daily delivery/pick up from UPS,
FedEx and USPS

ENTERTAINMENT / ATTRACTIONS

Ft. Lauderdale has many choices for entertainment all year around from beaches to museums and everything in-between. Here are just a few choices.

AutoNation IMAX Theatre
(at the Museum of Discovery & Science)
401 S.W. 2nd Street
Fort Lauderdale, FL 33312
954-467-6637

Greater Ft. Lauderdale Convention &
Visitors Bureau
954-765-4466
www.sunny.org

Museum of Art Fort Lauderdale
One East Las Olas Blvd.
Fort Lauderdale, FL 33301
954-525-5500

Billie Swamp Safari
(Everglades Tours, Airboat rides, Swamp
Buggy rides)
800-GO-SAFARI
www.billieswamp.com/

Seminole Hard Rock Hotel & Casino
1 Seminole Way
Hollywood, Florida 33314
954-327-7625

DINING / NIGHTLIFE

Please check out the “Go Riverwalk” and “Riverwalk A & E” websites below for more information on restaurants and nightlife surrounding the Broward Center.

<http://www.goriverwalk.com/>

<http://www.riverwalkartsandentertainment.com/>

The Production Department has menu books available which includes local restaurant menus, many with take-out and delivery available. There are many restaurants, bars and clubs within walking distance of the Broward Center. Below are the Preferred Restaurant Partners of the Broward Center that offer exclusive discounts:

The Chimney House

701 W Las Olas Blvd

Fort Lauderdale, FL 33312

954-900-5352

www.thechimneyhouse.net

Walking Distance: .01 mile (next to BCPA)

Himmarshee Public House

201 SW 2nd Street

Fort Lauderdale, FL 33301

954-616-5275

<http://publichouseftl.com/>

Walking Distance: .02 mile

Tarpon Bend (restaurant & bar)

200 SW 2nd Street

Fort Lauderdale, FL 33301

954-523-3233

www.tarponbend.com

Walking Distance: .04 mile

Grille 401

401 E Las Olas Blvd

Fort Lauderdale, FL 33301

954-767-0222

www.grille401.com

Walking Distance: Less than 1 mile

YOLO

333 E Las Olas Blvd

Fort Lauderdale, FL

954-523-1000)

www.yolorestaurant.com

Walking Distance: 1.1 mile

The Royal Pig Pub

350 East Las Olas Boulevard

Fort Lauderdale, FL 33301

954-617-7447

<http://www.royalpigpub.com/>

Walking Distance: 1.2 Miles

15th Street Fisheries

1900 SE 15th Street

Fort Lauderdale, FL 33316

954-763-2777

www.15streetfisheries.com

Walking Distance: 2.77 miles

Bimini Boatyard

1555 SE 17th Street

Fort Lauderdale, FL 33316

954-525-7400

www.biminiboatyard.com

Walking Distance: 3.01 miles

Café Vico

1125 N. Federal Highway

Fort Lauderdale, FL 33304

954-565-9681

www.cafevicorestaurant.com

Distance: 3.1 miles

FLORISTS

Ann's Florist & Greenhouse
1001 E Las Olas Blvd
Fort Lauderdale, FL
954-761-3334

A Basket Affair
830 E. Oakland Park Blvd, Suite 101
Oakland Park, FL 33334
954-567-2052

GYM

Bally Total Fitness
750 W Sunrise Blvd
Fort Lauderdale, FL 33312
954-764-8666

The Firm Fitness Center
928 N Federal Hwy
Fort Lauderdale, FL 33304
954-767-6277

The Fitness Company
110 SE 6th St – 7th Floor
Contact Rhonda 954-761-1110
FAX 954-463-4952

LA Fitness
3825 N. Federal Hwy.
Contact: Matt 954-567-2727
Day Passes \$15.00

HAIR

Las Olas Barber Shop
1400 E. Las Olas Blvd.
Ft. Lauderdale, FL 33301
Open 7 days a week, will come to theatre
954-462-1351

Source Spa & Salon
1881 NE 26th Street, Suite 30
Wilton Manors, Florida 33305
954-568-1998

HARDWARE/SUPPLIES

Home Depot
1000 NE 4th Street
Fort Lauderdale, FL 33304

McDonald's Hardware
245 SW 24 Street
Fort Lauderdale, FL 33315
954-463-2000

Miami Stagecraft (sales & rentals)
2855 East 11th Ave
Hialeah, FL 33013
305-836-9356
(9:00 am – 5:00 pm M-F)

Stage Equipment and Lighting, Inc.
12250 NE 13th Court
Miami, FL 33161
(305) 891-2010

LAUNDRY / DRY CLEANING

Dry Cleaning Depot
730 W. Broward Blvd
954-522-1126

Fashion Cleaners
2427 W. Broward Blvd
954-583-8225

SHOPPING

Publix (Grocery and Pharmacy)

601 South Andrews Avenue
Fort Lauderdale, FL 33301
954-728-8330
(7:00am – 11:00pm)

Whole Foods Market

2000 N Federal Hwy
Fort Lauderdale, Florida 33305
954-565-5655
Mon - Sun: 8am - 10pm

Walgreen's Pharmacy

700 Broward Blvd
Fort Lauderdale 33301
954-463-9937
(7:00am- 11:00pm)

Galleria Mall

2414 East Sunrise Blvd
Fort Lauderdale, Florida 33304
Phone: 954-564-1015

The Fresh Market

424 N Federal Hwy, Fort Lauderdale, FL
33301
954-763-1250
Mon - Sun: 8am - 10pm

CVS/Pharmacy

1 North Federal Highway
Fort Lauderdale, FL 33301
954-524-0500

7-11

460 W Broward Blvd,
Fort Lauderdale, FL
954-467-3856
(24 Hour)

Sawgrass Mills Mall (Outlet Mall)

12801 West Sunrise Blvd
Sunrise, FL 33323
954-846-2350

MASSAGE (will come to theater or housing)

James Perc
(Swedish and Deep Tissue massage; Hot Stone)
Lic # MA43130
954-534-6611
bodyworkbyjim@yahoo.com

Lawrence Zwarich
(Swedish and Deep Tissue massage)
Lic # MA43125
954-383-8891
cdnlar@hotmail.com

Diva's Day Spa
Full-service Spa located next door to the Broward Center in the Symphony building. Will come to the theater for massages.
954-522-1141 x 6 or 954-771-9772
(ask for Jacki and let her know you are a performer at the Broward Center for a discount on services)

Emma Stevenson
(Deep tissue, sport, craniosacral)
Lic # MA79390
954-336-5516
message.warrior77@gmail.com

MEDICAL

Hospitals and clinics are listed first, followed by Doctors (listed alphabetically by specialty)

HOSPITALS

Broward General
1600 South Andrews Avenue
Fort Lauderdale FL 33304
954-355-4400

Imperial Point Medical Center
6401 North Federal Highway
Fort Lauderdale, FL 33308
954-776-8500

URGENT CARE

Broward Health Urgent Care
200 Northwest 7th Avenue
Fort Lauderdale, FL 33311
954-759-6794

Concentra Urgent Care Center
1347 S. Andrews Avenue
Fort Lauderdale, FL 33304
954-767-9999

Health Med Centers (Cash/Credit Only)
1493 SE 17th Street
Fort Lauderdale, FL 33316
954-525-7595

CHIROPRACTIC

Downtown Chiropractic Center
1601 E. Broward Blvd.
Ft. Lauderdale, FL
954-463-1166

Marcus Chiropractic Center
Dr. Peter Marcus
2710 E. Oakland Park Blvd, FT L 33306
954-566-3027 (Will make House Calls)

Dr. Patrick Helmer - Chiropractor
9532 Griffin Rd. Suite 1800
Cooper City, FL 33328
954-434-1800

DENTAL

Dr. Ari Arocha
113 SW 11th Ct
Ft Lauderdale, FL 33315
(954) 463-7972

Dr. Thomas Jeson
3000 E. Commercial Blvd.
Ft. Lauderdale, FL 33308
954-491-1904
Fax – 954-772-3453

Dr. Larry Levinson
9 SW 17th St.
Ft. Lauderdale, FL 33315
954-524-3117

Dr. Jeffrey Bartlett
2440 E. Sunrise
In the Galleria Mall
954-566-8668

DERMATOLOGY

Dr. Babinski
1102 E. Broward Blvd.
Fort Lauderdale, FL 33312
954-463-5406
*Will make emergency theatre calls

Dr. Smith / Las Olas Dermatology
800 E. Broward Blvd. Suite 507
Ft. Lauderdale, FL 33301
954-763-4331

EAR / NOSE/ THROAT

Dr. Herbert Moselle, ENT
201 NW 82nd Ave.
Plantation, FL 33324
954-472-1212

Dr. Bruce Weissman* - ENT, Voice Care
2100 Hallandale Beach Blvd Suite 405
Hallandale, FL 33009
o: 954-454-0544 cell: (305) 505-0666;

EYE CARE

Dr. Goldberg and Dr. Nolan
Eye Physician & Surgeon
2334 NE 53rd Street
Ft. Lauderdale, FL 33308
(954)776-2020

FAMILY/GENERAL PRACTICE

Dr. Ed Grenet - Health-Med Centers
1493 SE 17th Street
Ft. Lauderdale, FL 33316
954-525-7595 fax# 954-525-7599

Dr. Harvey Kleiner, DO
8890 W Oakland Park Blvd, Suite 100
Fort Lauderdale, FL 33351
954-741-3304

Dr. Myron Davidson
2500 NE 15th Ave
Wilton Manors, FL
954-533-5382

Dr. Glenn Moran, DO
Plantation Family Medical Assocs
201 Northwest 82nd Avenue Suite 401
Plantation, FL 33324
954-472-5100

OB/GYN

Dr. Amy Sonnenblick
954-635-6243

Dr. Trudi Fahey at Broward Medical Center
954-467-2013

All Women's Health
954-452- 5850

ORTHOPEDICS

Dr. Bruce Fletcher
Northwest Broward Orthopedic Associates
5901 Colonial Dr, Suite 201
Pompano Beach, FL 33063
954-979-3255

YOGA

Mandala Yoga Center
2449 NE 13th Ave.
Wilton Manors, FL 33305
973-573-2663
Mandalayogacenter.com